

ZIKMUND & HAVELKA

OD ROKU 1992 **VYRÁBÍME**

UCELENÉ **KOMPLETY**

KOVÁNÍ — VÝROBA I NA

ZAKÁZKU — **PRO** KLASICKÁ

KUCHYŇSKÁ **KACHLOVÁ**

KAMNA, PECE A UDÍRNY.



KOVÁNÍ
NA KUCHYŇSKÁ
KACHLOVÁ KAMNA

2	pečicí trouby CN
4	příkládací štíty CN
5	uhláky CN
6	pečicí trouby CC
7	pečicí trouby CC / uhláky CC
8	příkládací štíty CC
9	kování bílý smalt EB
10	uhláky bílý smalt EB / černý smalt EC
11	kování černý smalt EC
12	kování bílý smalt RB
13	uhláky bílý smalt RB / černý smalt RC
14	kování černý smalt RC
15	kování bílý smalt OB
16	uhláky bílý smalt OB / černý smalt ORC
17	kování černý smalt ORC
18	kování HCC
19	uhláky HCC / kamnovce
20	kování pro udírny CN
21	kování pro udírny CC
22	dveře k peci na chleb CN / CC
23	topné štíty k výměníkům CN / CC
24	rámy / plotny
25	příslušenství
26	kouřovody ø 150 mm
26	kouřovody ø 150 mm C
28	biotopeniště

PEČÍCI TROUBY CN

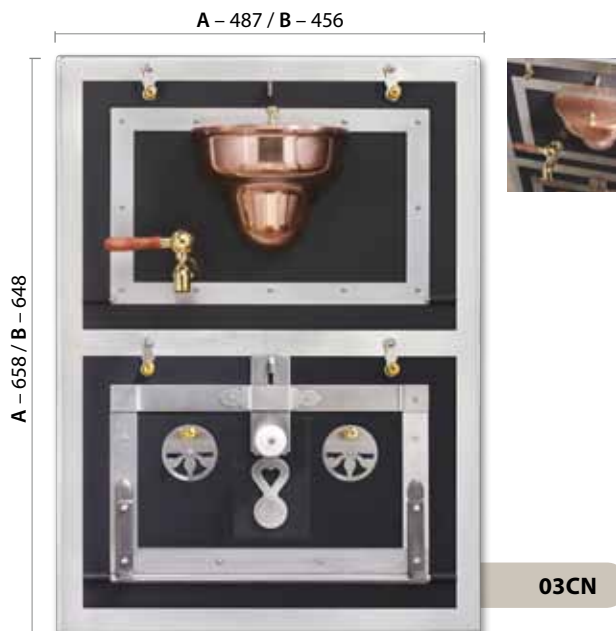
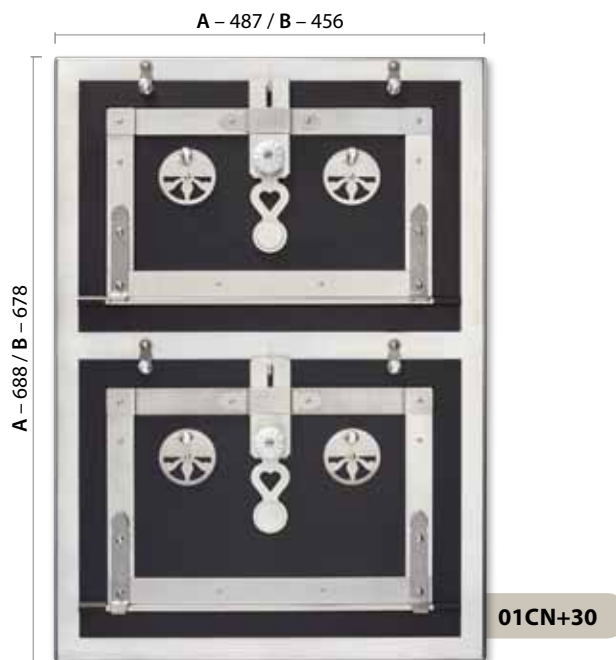
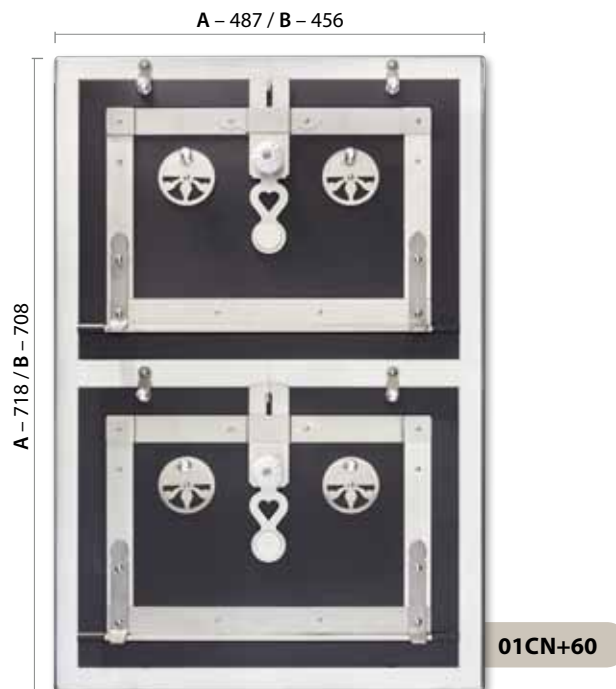
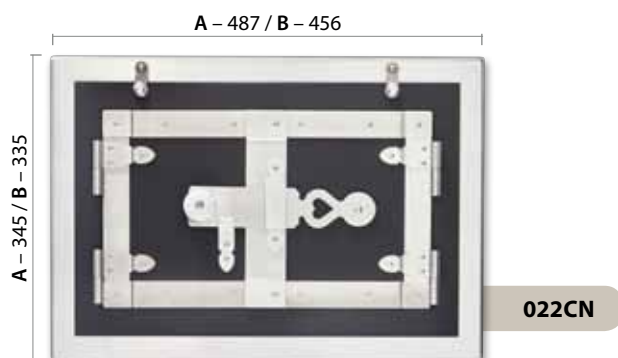
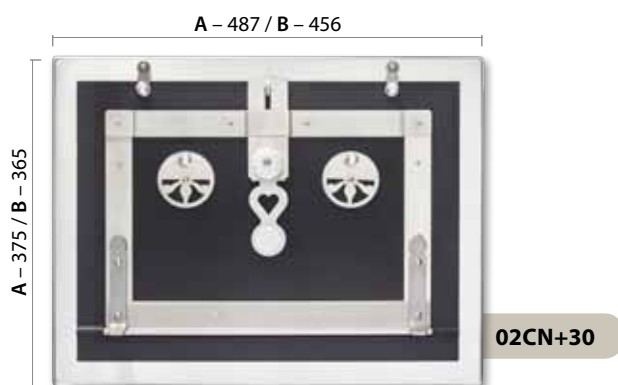
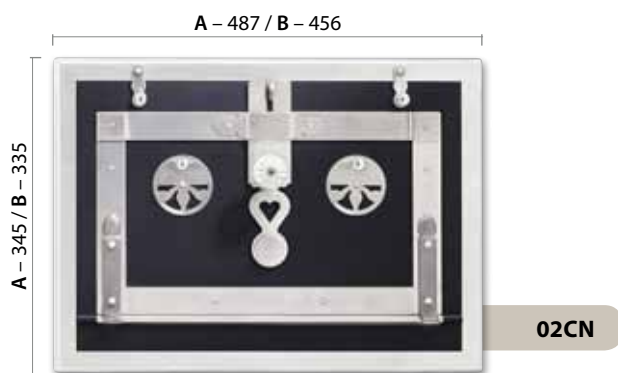
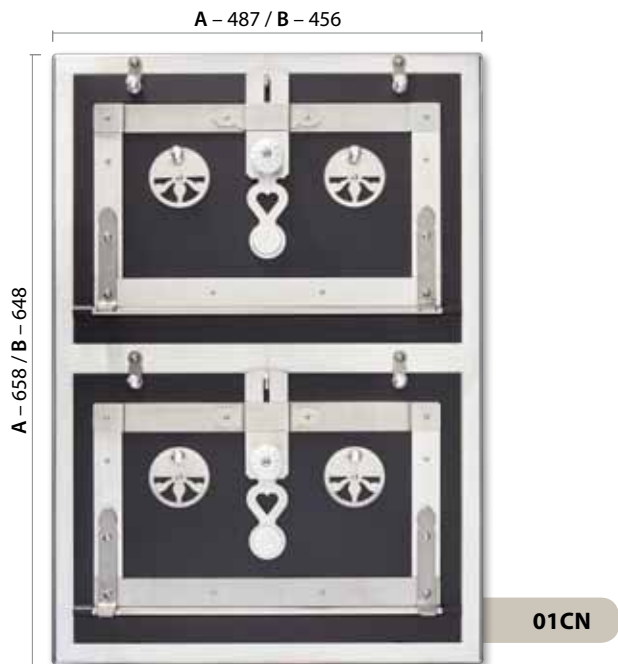

PEČÍCÍ TROUBY CN

provedení **CN** – černá mat, nerez s keramickými úchyty

Všechny trouby jsou vydělavací. Trouba **06** je nevydělávací, má vytahovací dno. Rozměr plášťů trouby: š. 355, v. 210 (240), hl. 500 (550, 600) mm.

Základní provedení se dodává s keramickými úchyty „Po“ kování dodáváme i s úchyty duralovými „Al“ nebo mosaznými „Ms“

CN.Ms - mosazné

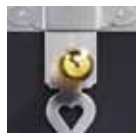

CN.AI - duralové



CN.Po - porcelánové

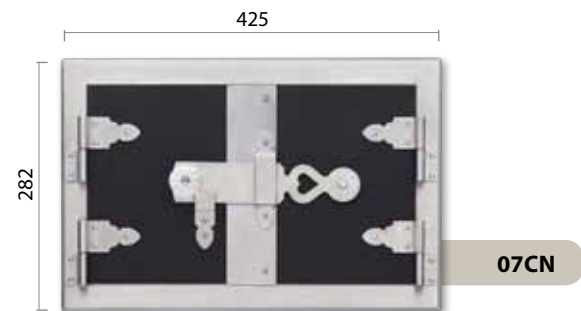
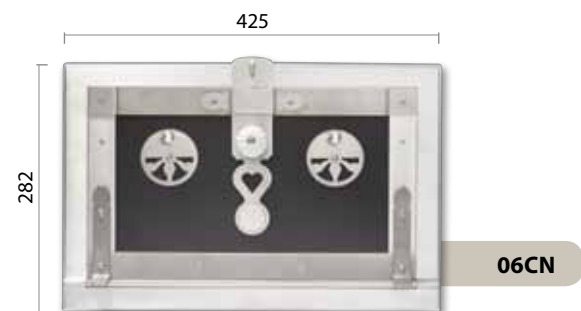
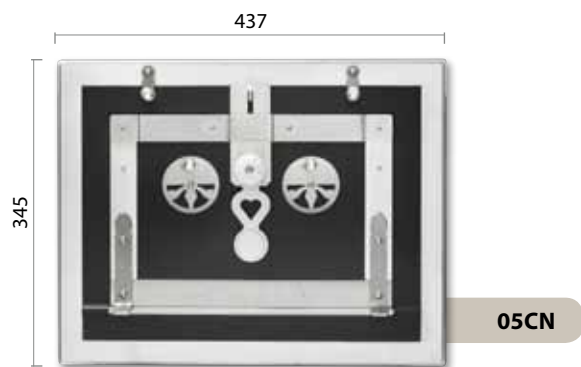
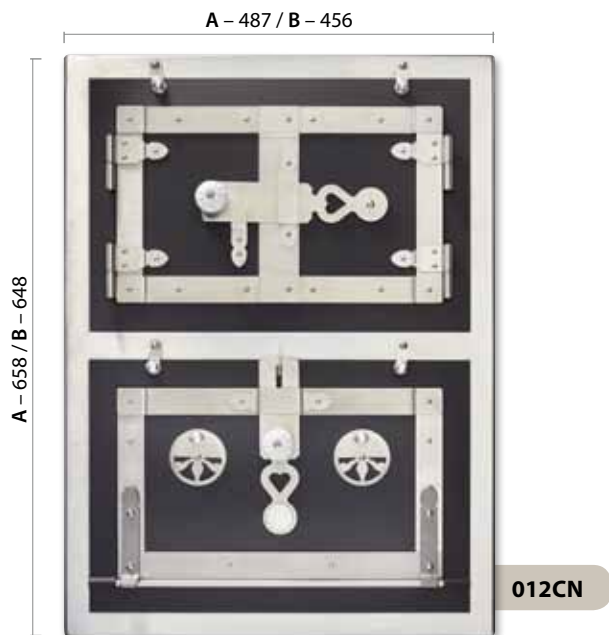
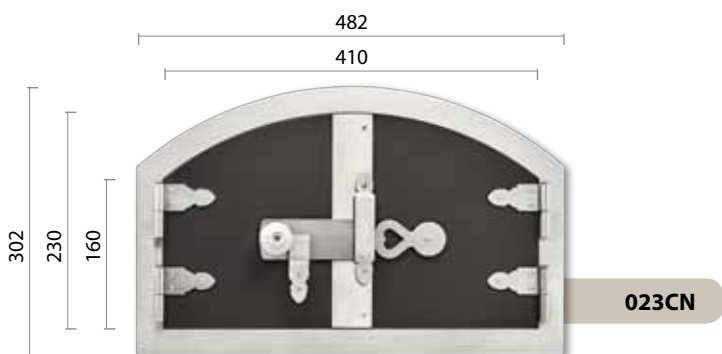

VYMETACÍ DVIŘKA

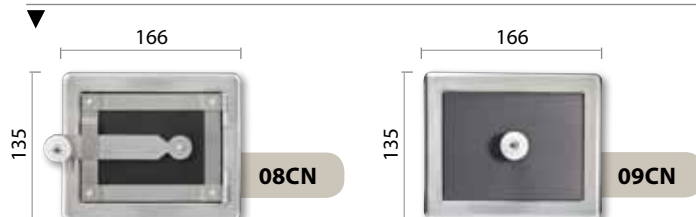

PŘÍKLÁDACÍ ŠTÍTY CN

provedení **CN** – černá mat, nerez s keramickými úchyty

Základní provedení se dodává s keramickými úchyty, „_Po“
kování dodáváme i s úchyty duralovými „_Al“ nebo mosaznými „_Ms“

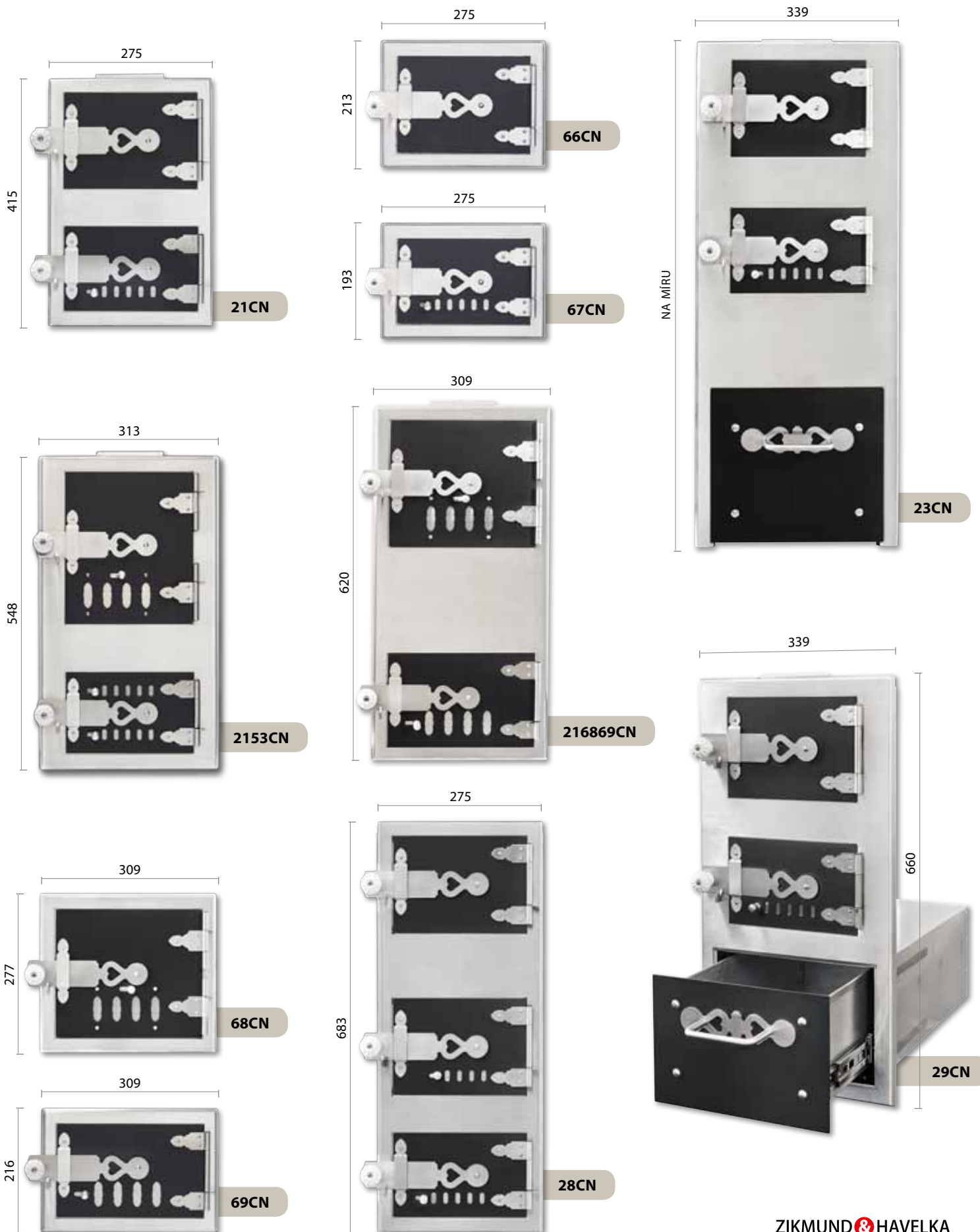

UHLÁKY CN

provedení **CN** – černá mat, nerez

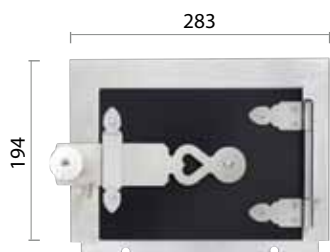

25CN Příkládací dvířka pro kamna na nožkách



26CN Popelník výsuvný
vnější rozměry: š. 270, h. 400, v. 145 mm.

27CN Bedna na popelník, š. 310, h. 425, v. 145 mm.

UHLÁK NA KOLEČKÁCH

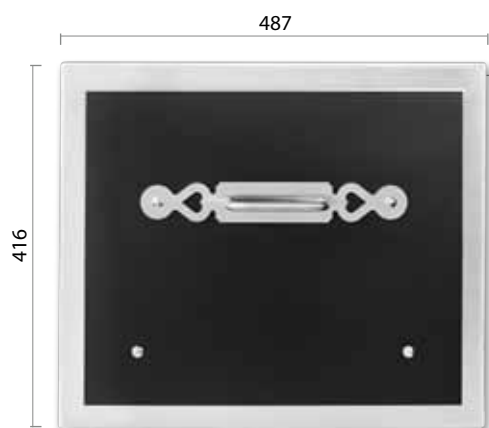
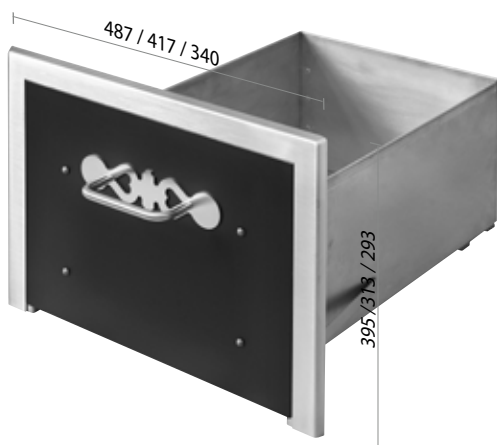

35CN

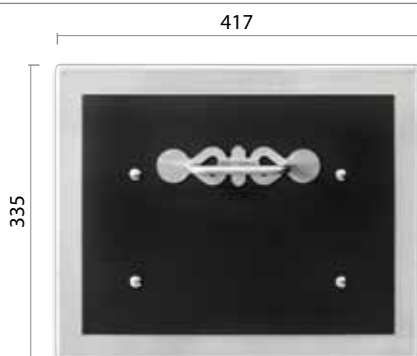

36CN

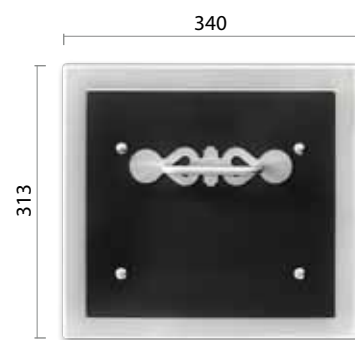

37CN

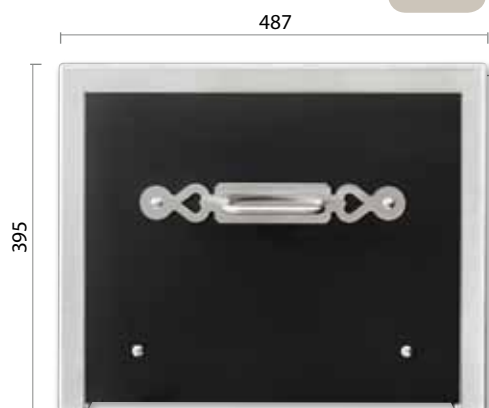

31CN



32CN

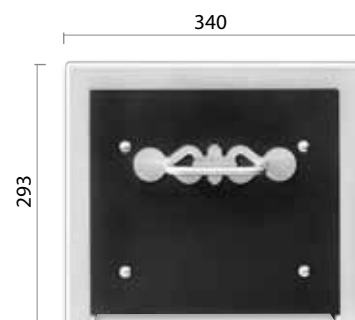

33CN

UHLÁK NA VÝSUVĚCH

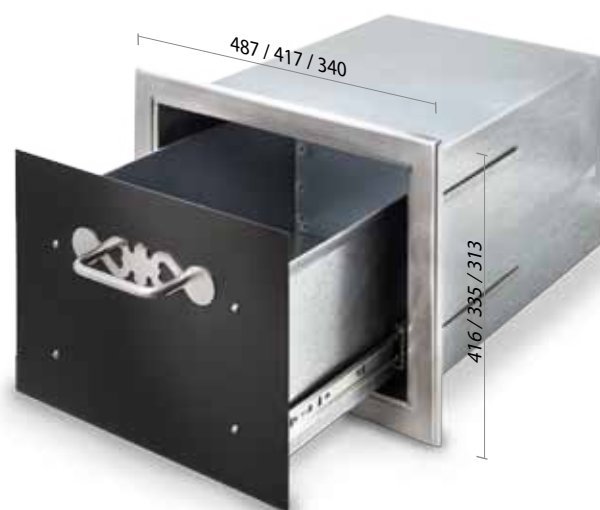

UHLÁKY NA VÝSUVĚCH

UHLÁKY NA KOLEČKÁCH

PEČÍCÍ TROUBY CC

provedení **CC** – černá mat s keramickými úchyty

Všechny trouby jsou vydělavací. Trouba 06 je nevydělavací, má vytahovací dno
Rozměr plášťů trouby: š. 355, v. 210 (240), hl. 500 (550, 600) mm.

Základní provedení se dodává s keramickými úchyty „Po“
kování dodáváme i s úchyty duralovými „Al“ nebo mosaznými „Ms“

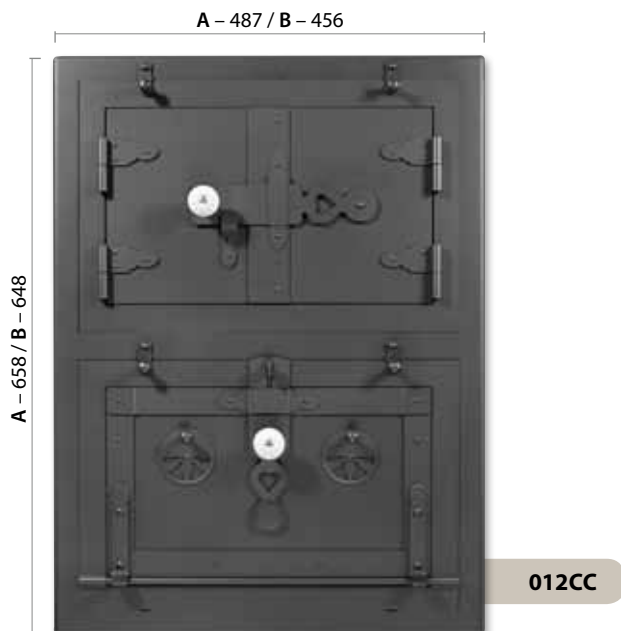
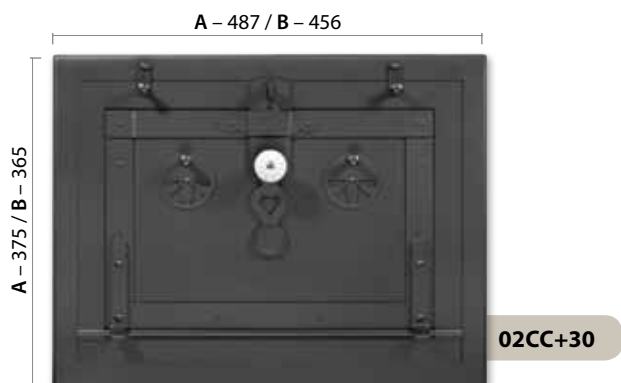
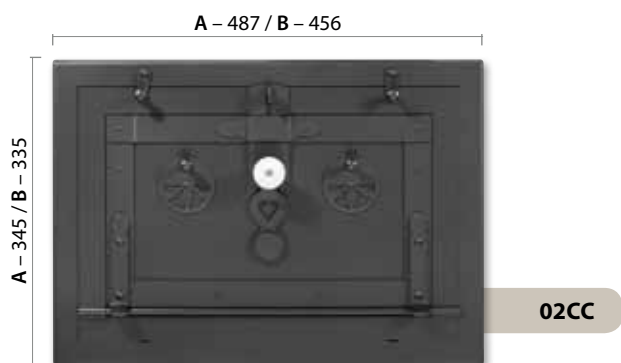

PEČÍCI TROUBY CC



05CC

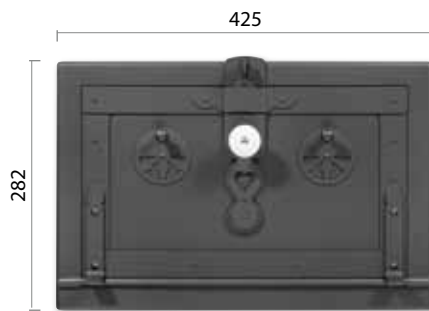

06CC

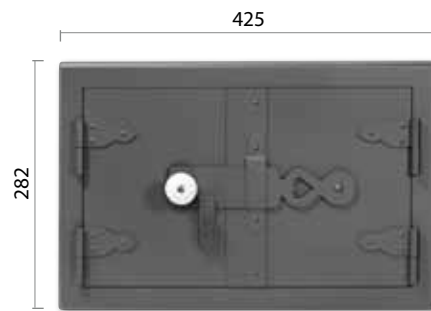

07CC

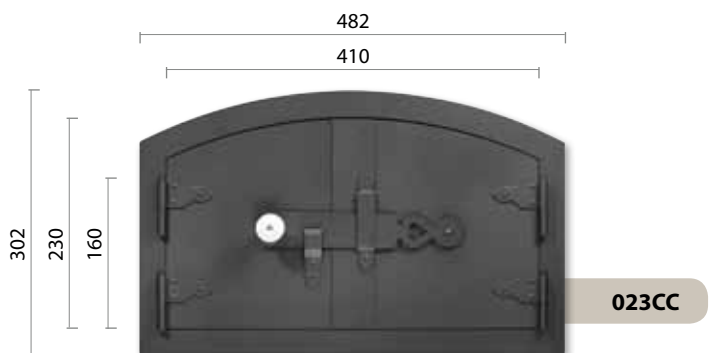

023CC

VYMETACÍ DVÍŘKA

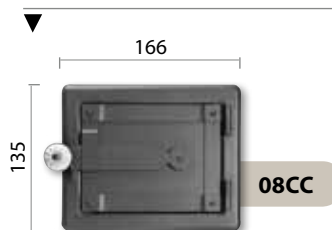

08CC

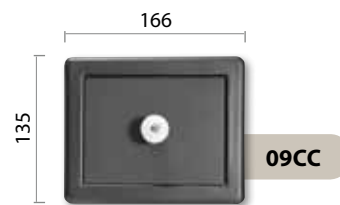

09CC

UHLÁKY CC



35CC

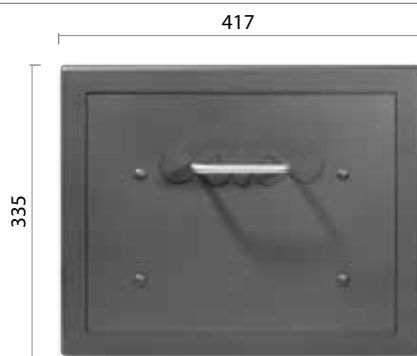

36CC

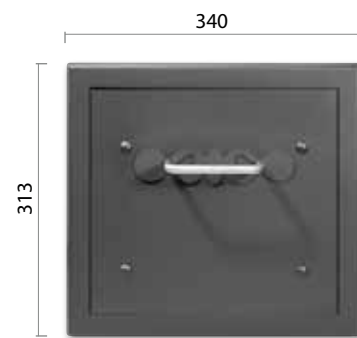

37CC

UHLÁKY NA VÝSUVECH



31CC



32CC

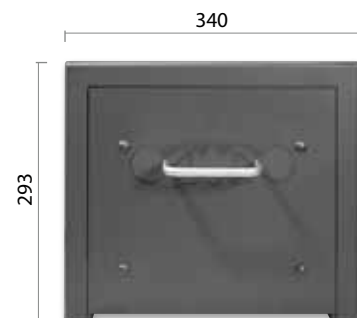

33CC

UHLÁKY NA KOLEČKÁCH

PŘÍKLÁDACÍ ŠTÍTY CC

provedení **CC** – černá mat, nerez s keramickými úchyty

Základní provedení se dodává s keramickými úchyty „Po“
kování dodáváme i s úchyty duralovými „Al“ nebo mosaznými „Ms“

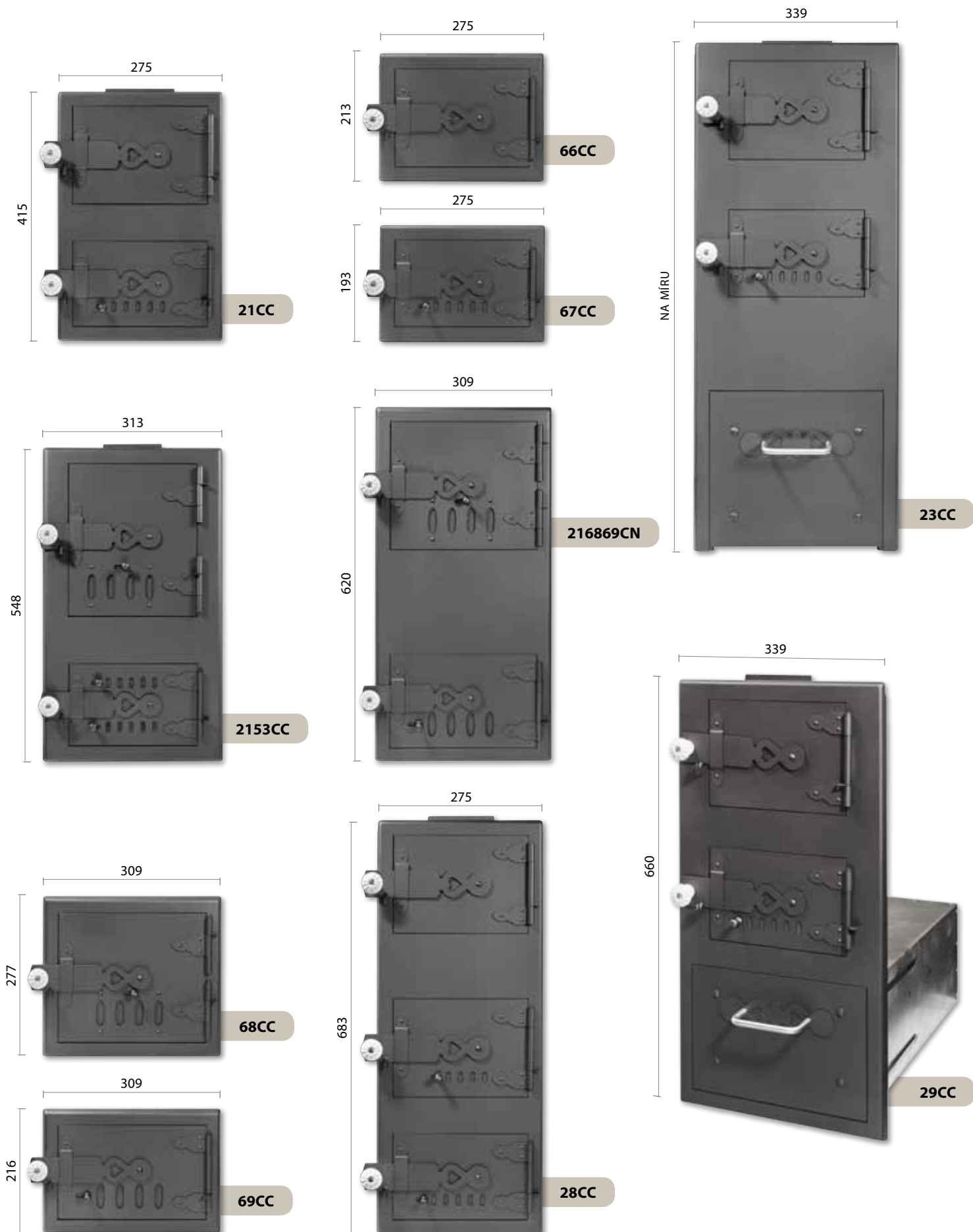

KOVÁNÍ BÍLÝ SMALT EB

provedení **EB** – bílá s keramickými úchyty

Všechny trouby jsou vydělavací.

Rozměr plášťů trouby: š. 355, v. 210 (240), hl. 500 (550, 600) mm.

Základní provedení se dodává s keramickými úchyty, „Po“ kování dodáváme i s úchyty duralovými „Al“ nebo mosaznými „Ms“

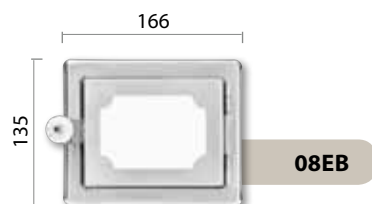
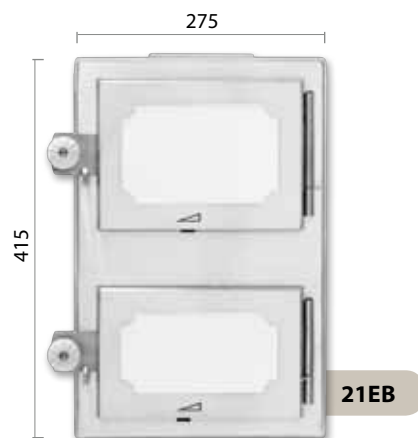

UHLÁKY BÍLÝ SMALT EB



UHLÁKY ČERNÝ SMALT EC



KOVÁNÍ ČERNÝ SMALT EC

provedení **EC** – černá s keramickými úchyty

Všechny trouby jsou vydělavací.

Rozeř pláštů trouby: š. 355, v. 210 (240), hl. 500 (550, 600) mm.

Základní provedení se dodává s keramickými úchyty, „Po“
kování dodáváme i s úchyty duralovými „Al“ nebo mosaznými „Ms“

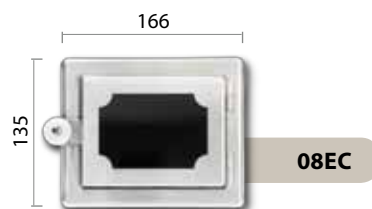
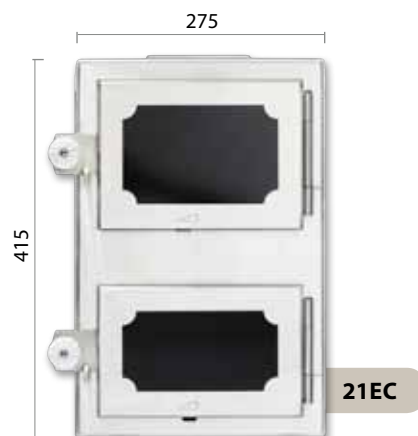
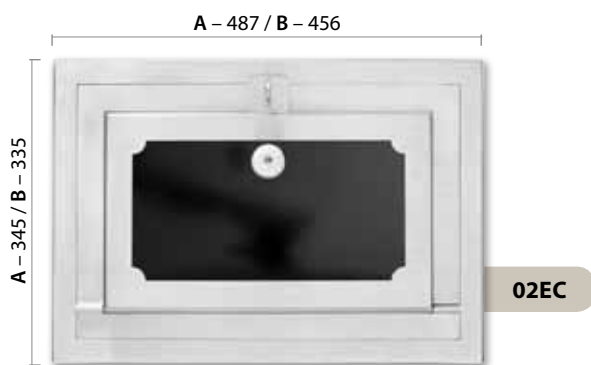
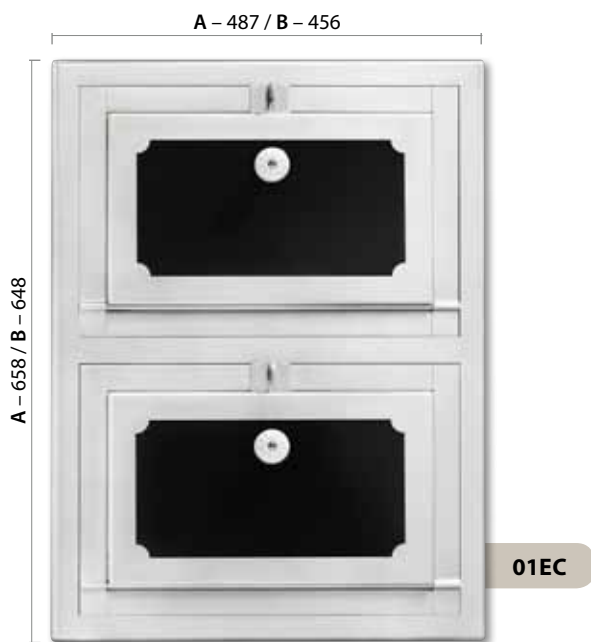

KOVÁNÍ BÍLÝ SMALT RB

provedení **RB** – bílá s keramickými úchyty

Všechny trouby jsou vydělavací.

Rozměr plášťů trouby: š. 355, v. 210 (240), hl. 500 (550, 600) mm.

Základní provedení se dodává s keramickými úchyty, „Po“
kování dodáváme i s úchyty duralovými „Al“ nebo mosaznými „Ms“

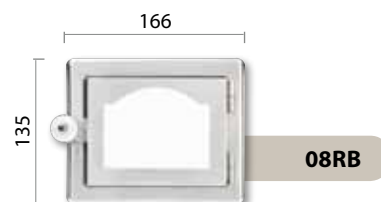
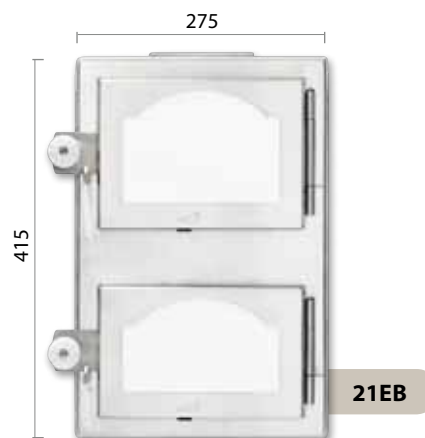
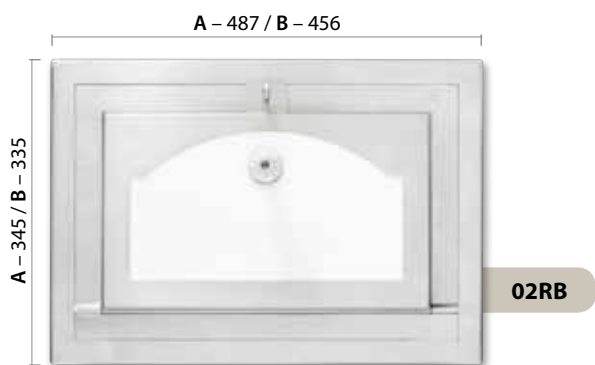

UHLÁKY BÍLÝ SMALT RB



UHLÁKY ČERNÝ SMALT RC



KOVÁNÍ ČERNÝ SMALT RC

provedení **RC** – černá s keramickými úchyty

Všechny trouby jsou vydělavací.

Rozeř pláštů trouby: ř. 355, v. 210 (240), hl. 500 (550, 600) mm.

Základní provedení se dodává s keramickými úchyty „Po“
kování dodáváme i s úchyty duralovými „Al“ nebo mosaznými „Ms“

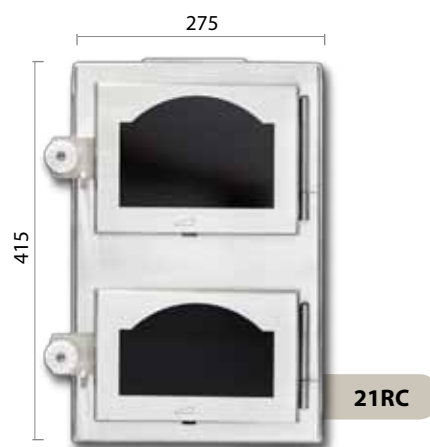
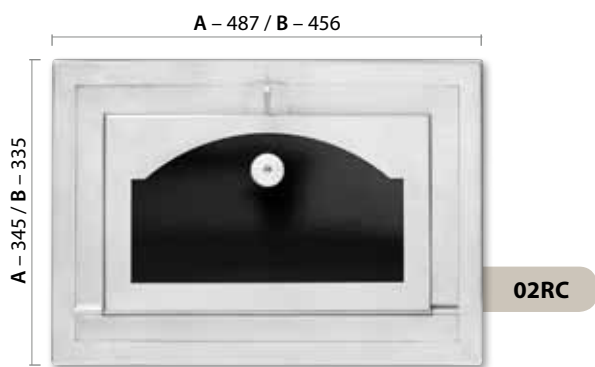

KOVÁNÍ BÍLÝ SMALT OB

provedení **OB** – bílá s keramickými úchyty

Všechny trouby jsou vydělavací.

Rozměr plášťů trouby: š. 355, v. 210 (240), hl. 500 (550, 600) mm.

Základní provedení se dodává s keramickými úchyty, „...Po“
kování dodáváme i s úchyty duralovými „...Al“ nebo mosaznými „...Ms“

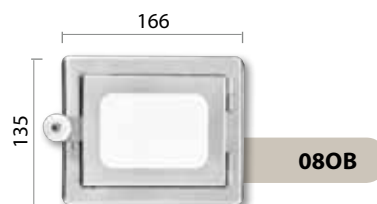
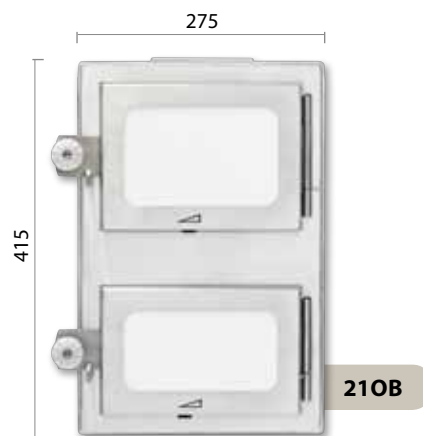

UHLÁKY BÍLÝ SMALT OB



35OB



36OB



37OB

UHLÁKY NA VÝSUVECH



31OB



32OB

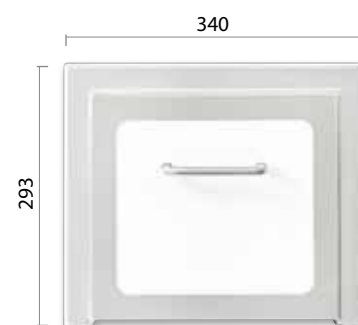

33OB

UHLÁKY NA KOLEČKÁCH

UHLÁKY ČERNÝ SMALT ORC



35ORC



36ORC

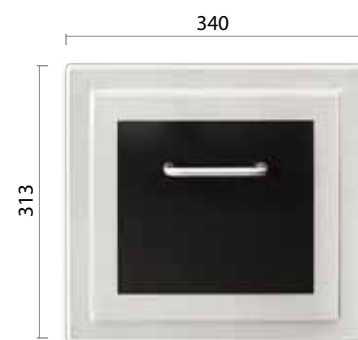

37ORC

UHLÁKY NA VÝSUVECH



31ORC



32ORC



33ORC

UHLÁKY NA KOLEČKÁCH

KOVÁNÍ ČERNÝ SMALT ORC

provedení **ORC** – černá s keramickými úchyty

Všechny trouby jsou vydělavací.

Rozeř pláštů trouby: ř. 355, v. 210 (240), hl. 500 (550, 600) mm.

Základní provedení se dodává s keramickými úchyty, „Po“
kování dodáváme i s úchyty duralovými „Al“ nebo mosaznými „Ms“

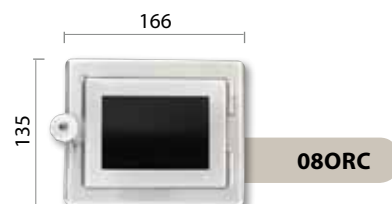
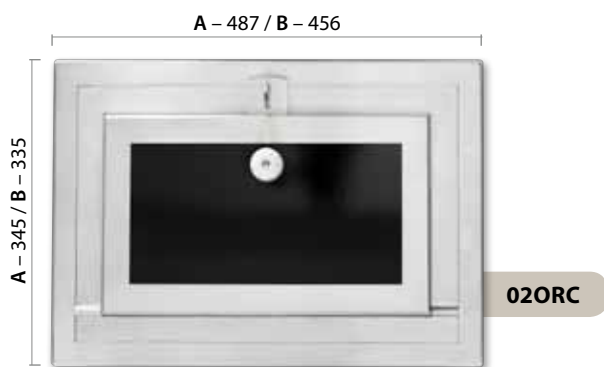
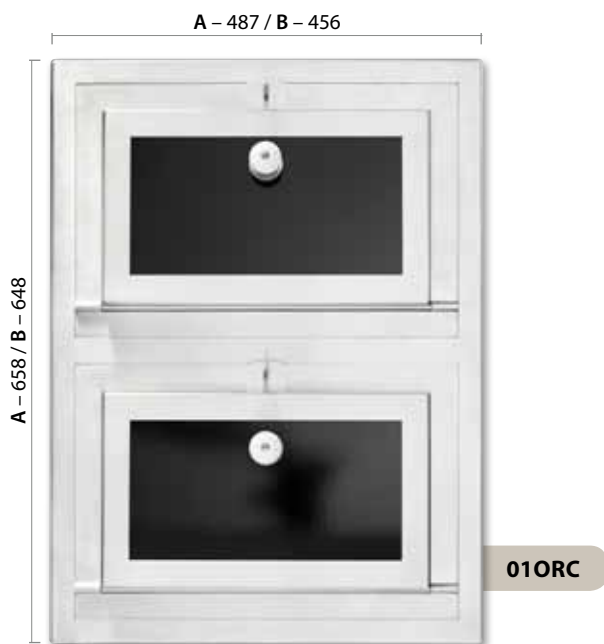

PEČÍCI TROUBY, PŘIKLÁDACÍ ŠTÍTY HCC

provedení **HCC** – černá mat s keramickými úchyty

Všechny trouby jsou vydělavací.

Rozeř pláštů trouby: ř. 355, v. 210 (240), hl. 500 (550, 600) mm.

Základní provedení se dodává s keramickými úchyty „Po“
kování dodáváme i s úchyty duralovými „Al“ nebo mosaznými „Ms“

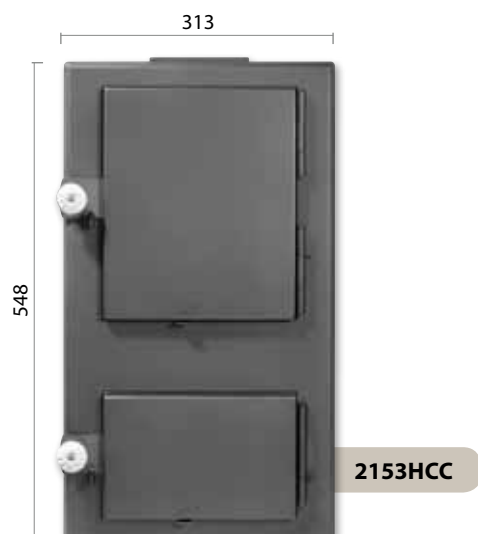
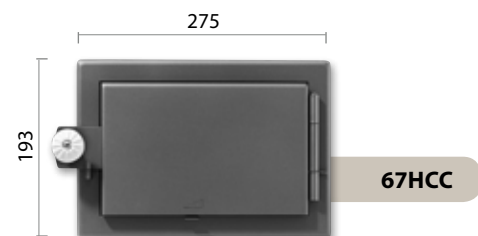
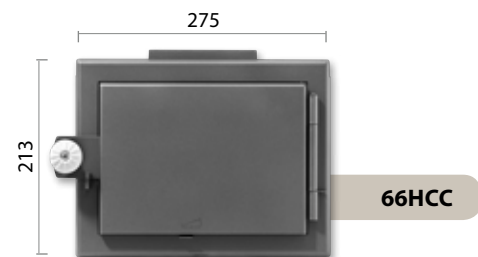
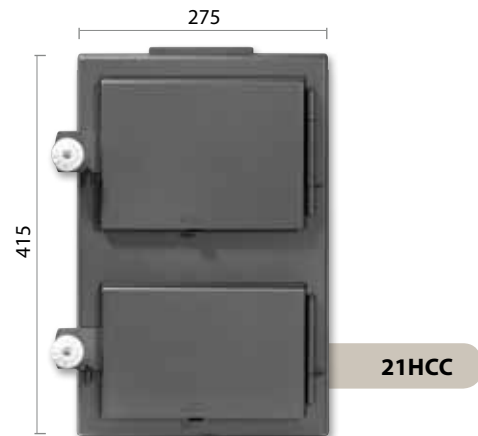
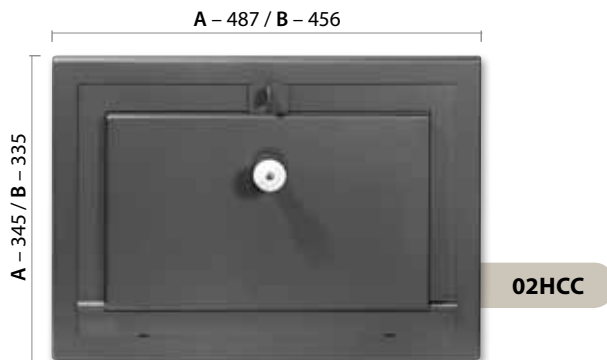

UHLÁKY HCC



35HCC

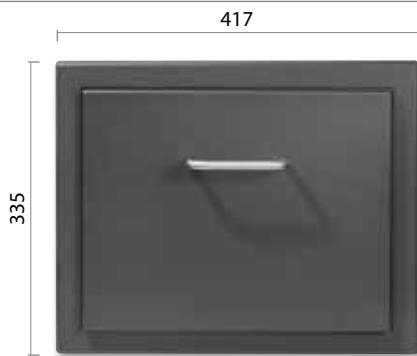

36HCC

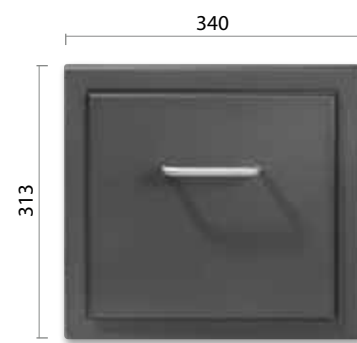

37HCC

UHLÁKY NA VÝSUVECH



31HCC

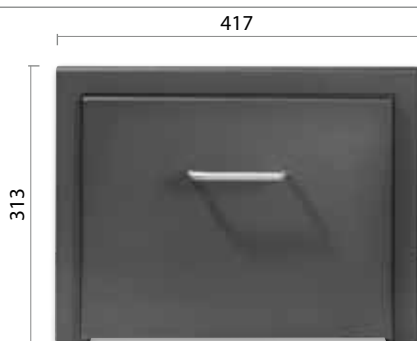

32HCC

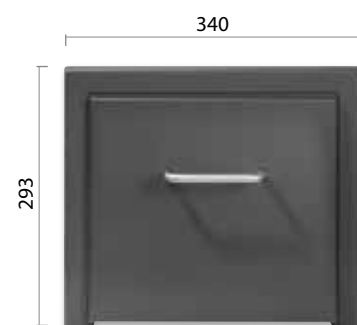

33HCC

UHLÁKY NA KOLEČKÁCH

KAMNOVCE

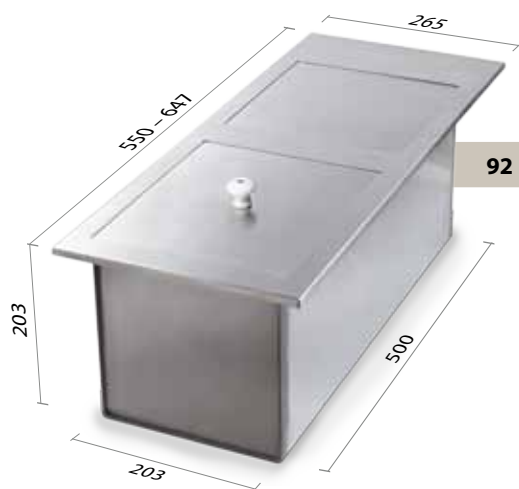

92



KOVÁNÍ PRO UDÍRNÝ CN

provedení **CN** – černá mat, nerez s keramickými úchyty

Základní provedení se dodává s keramickými úchyty, „Po“
kování dodáváme i s úchyty duralovými „Al“ nebo mosaznými „Ms“

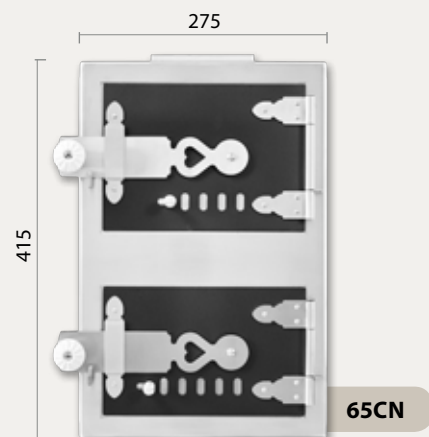
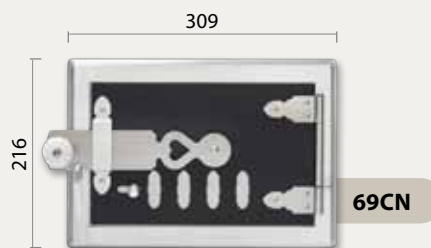
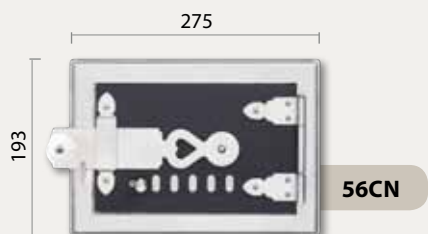
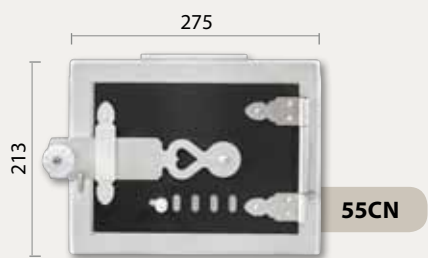
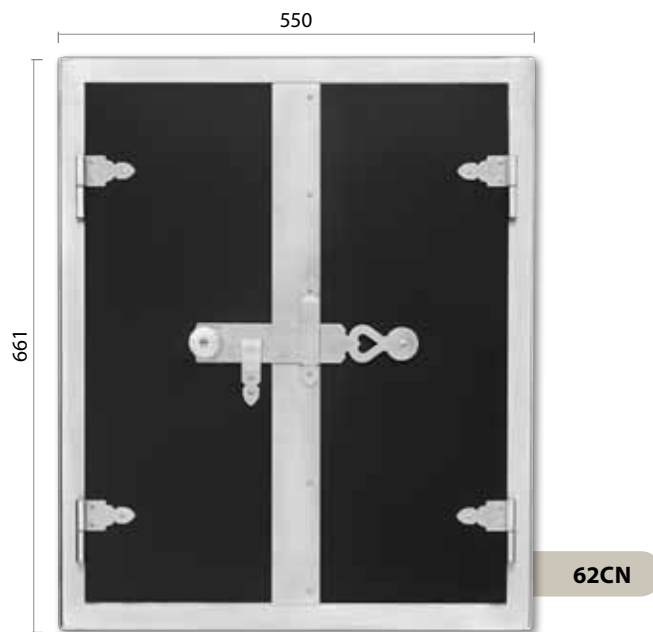
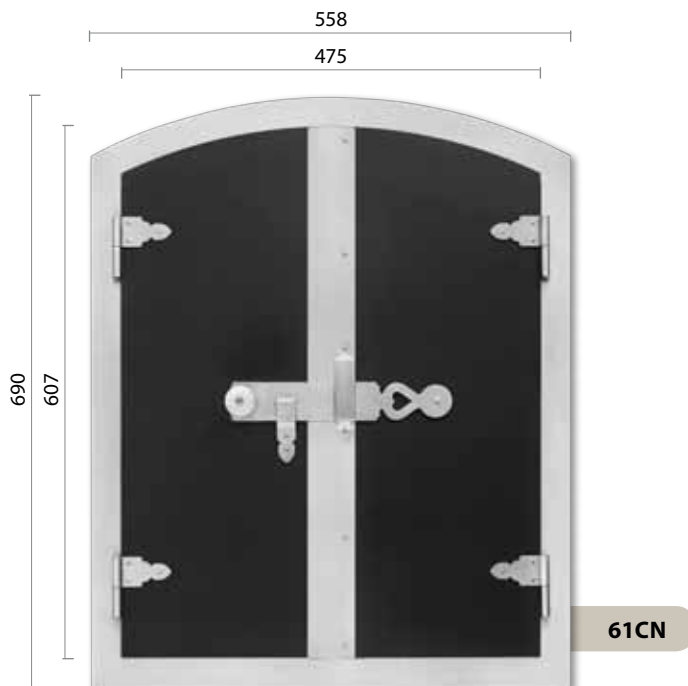
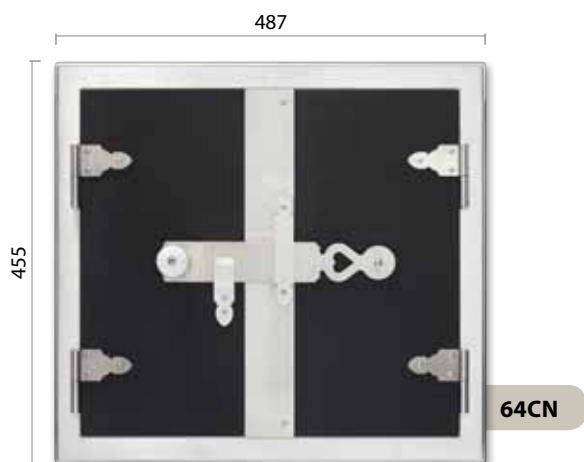

KOVÁNÍ PRO UDÍRNY CC

provedení **CC** – černá mat s keramickými úchyty

Základní provedení se dodává s keramickými úchyty, „Po“
kování dodáváme i s úchyty duralovými „Al“ nebo mosaznými „Ms“

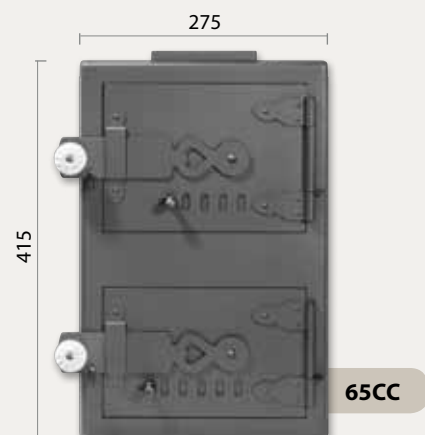
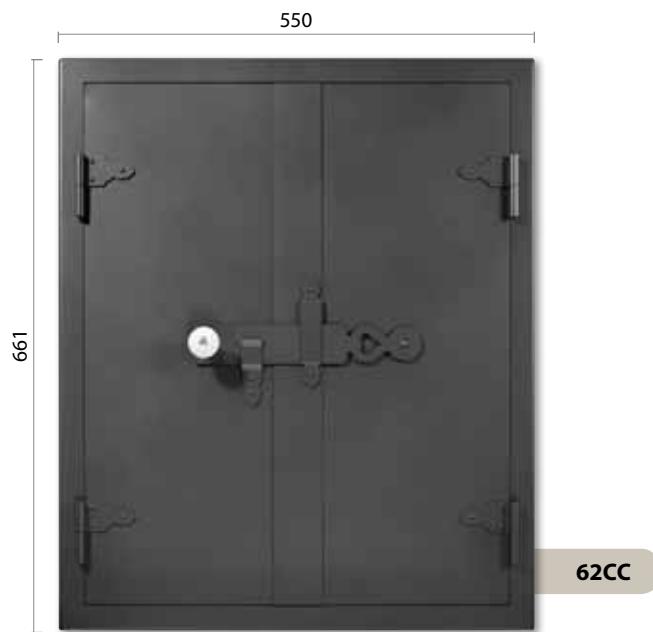
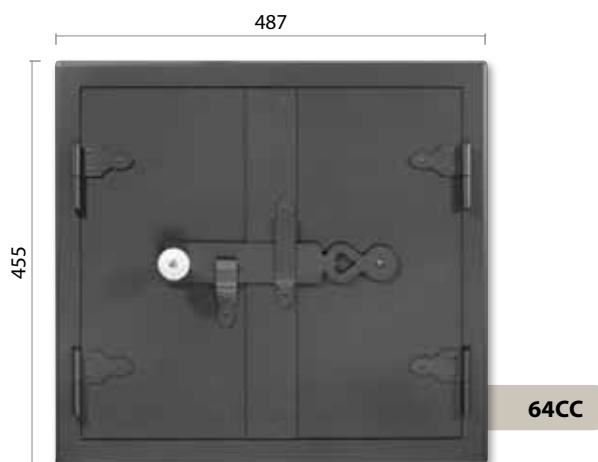
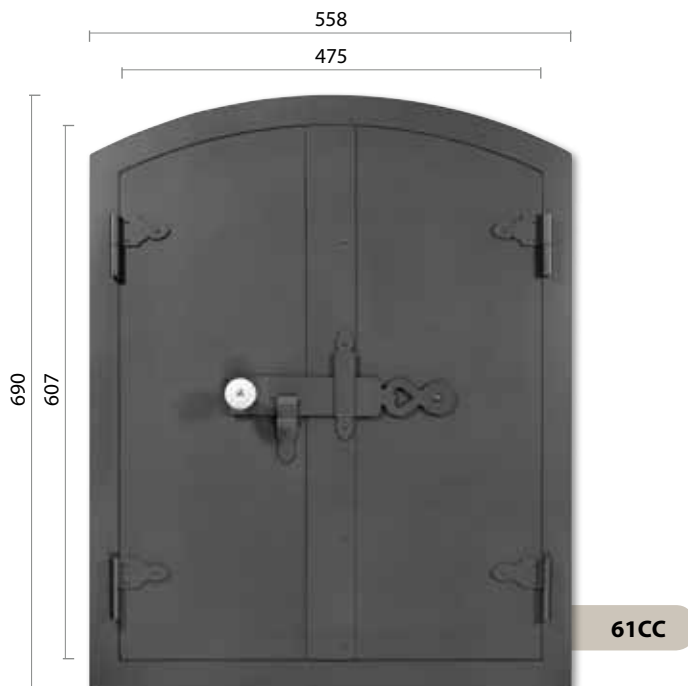
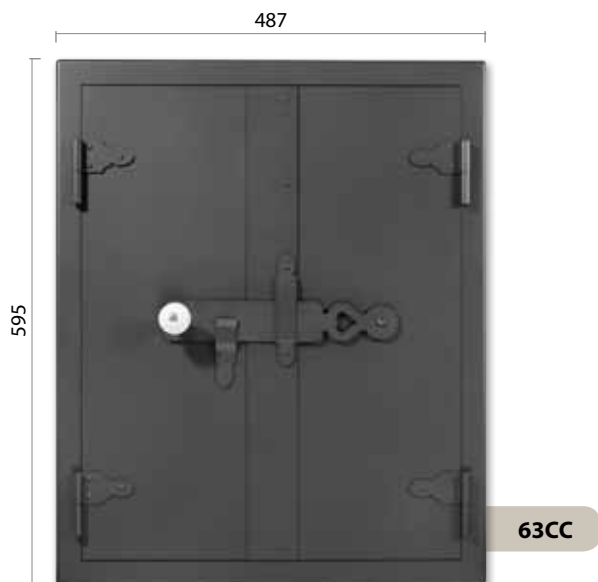

DVEŘE K PECI NA CHLEBA CN

provedení **CN** – černá mat, nerez s keramickými úchyty

Základní provedení se dodává s keramickými úchyty „Po“
kování dodáváme i s úchyty duralovými „Al“ nebo mosaznými „Ms“

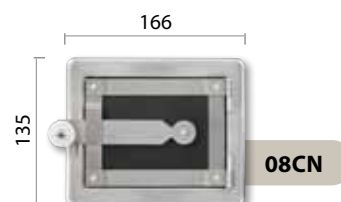
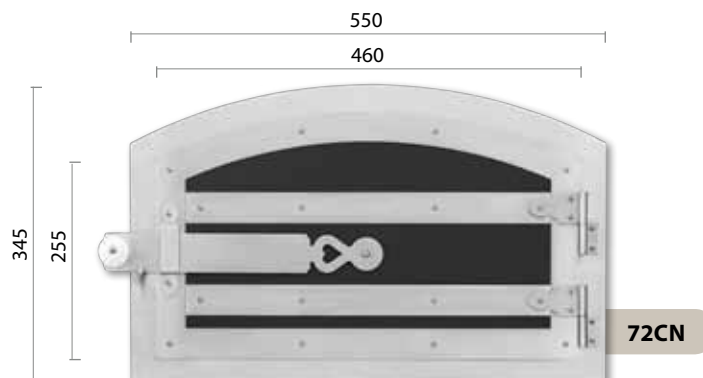

DVEŘE K PECI NA CHLEBA CC

provedení **CC** – černá mat s keramickými úchyty

Základní provedení se dodává s keramickými úchyty „Po“
kování dodáváme i s úchyty duralovými „Al“ nebo mosaznými „Ms“

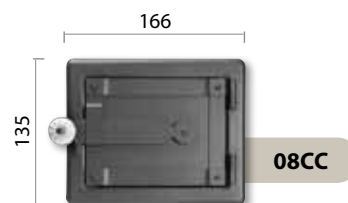
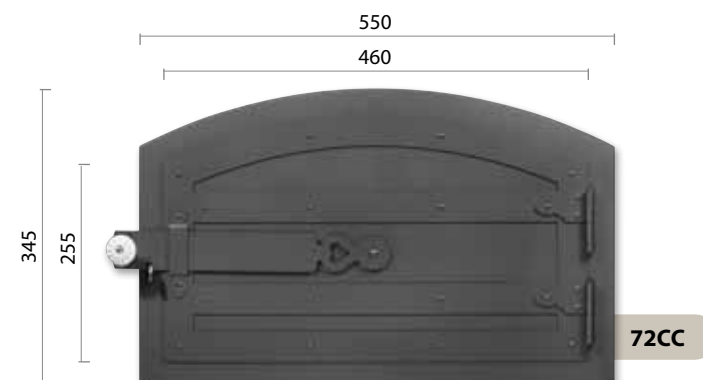
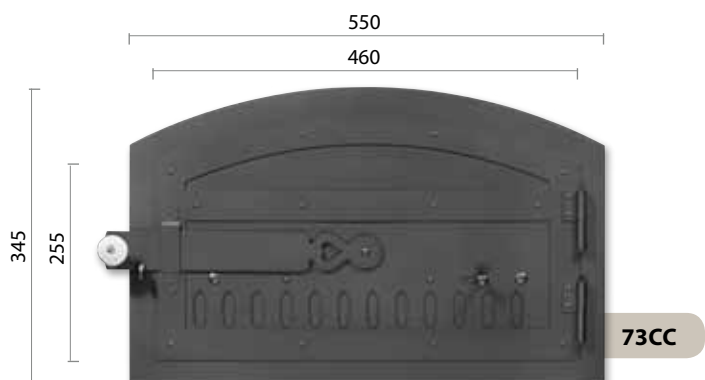

TOPNÉ ŠTÍTY K VÝMĚNÍKŮM CN

provedení **CN** – černá mat, nerez s keramickými úchyty

Základní provedení se dodává s keramickými úchyty „Po“
kování dodáváme i s úchyty duralovými „Al“ nebo mosaznými „Ms“

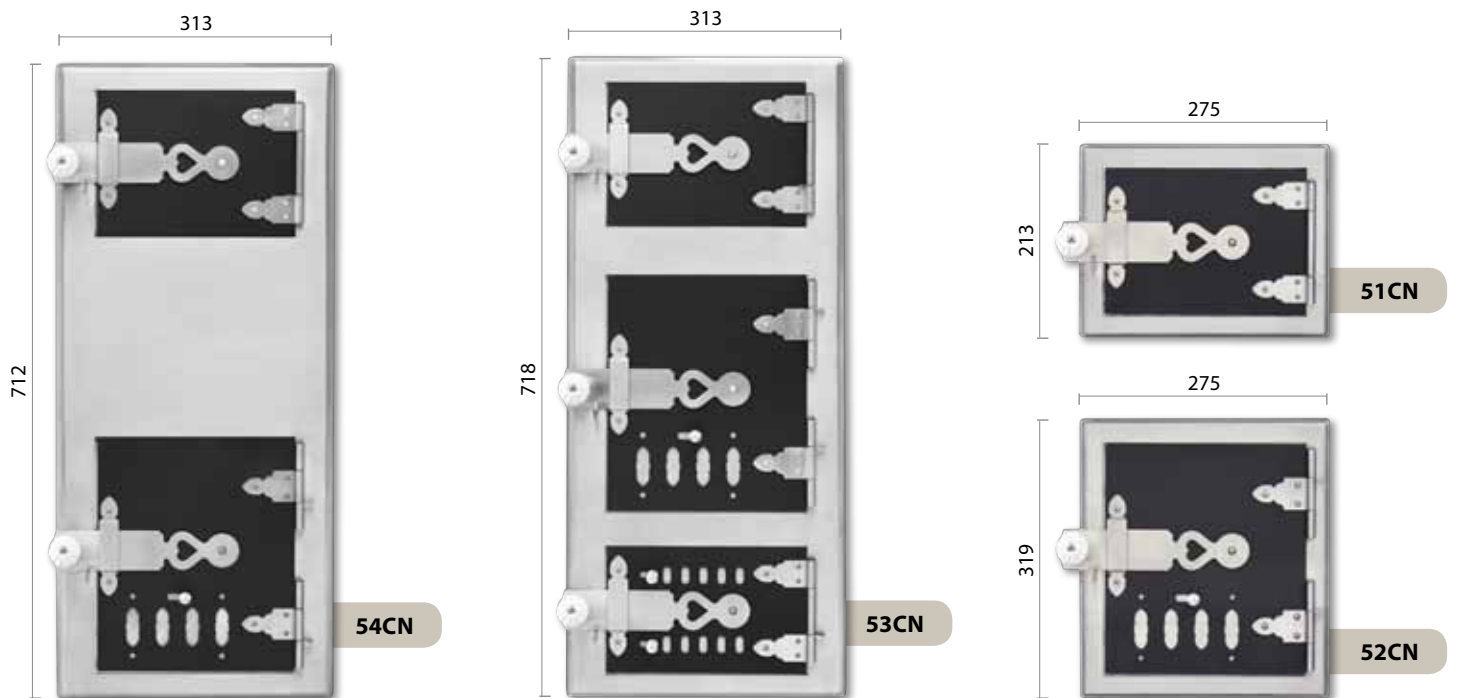

TOPNÉ ŠTÍTY K VÝMĚNÍKŮM CC

provedení **CC** – černá mat s keramickými úchyty

Základní provedení se dodává s keramickými úchyty „Po“
kování dodáváme i s úchyty duralovými „Al“ nebo mosaznými „Ms“

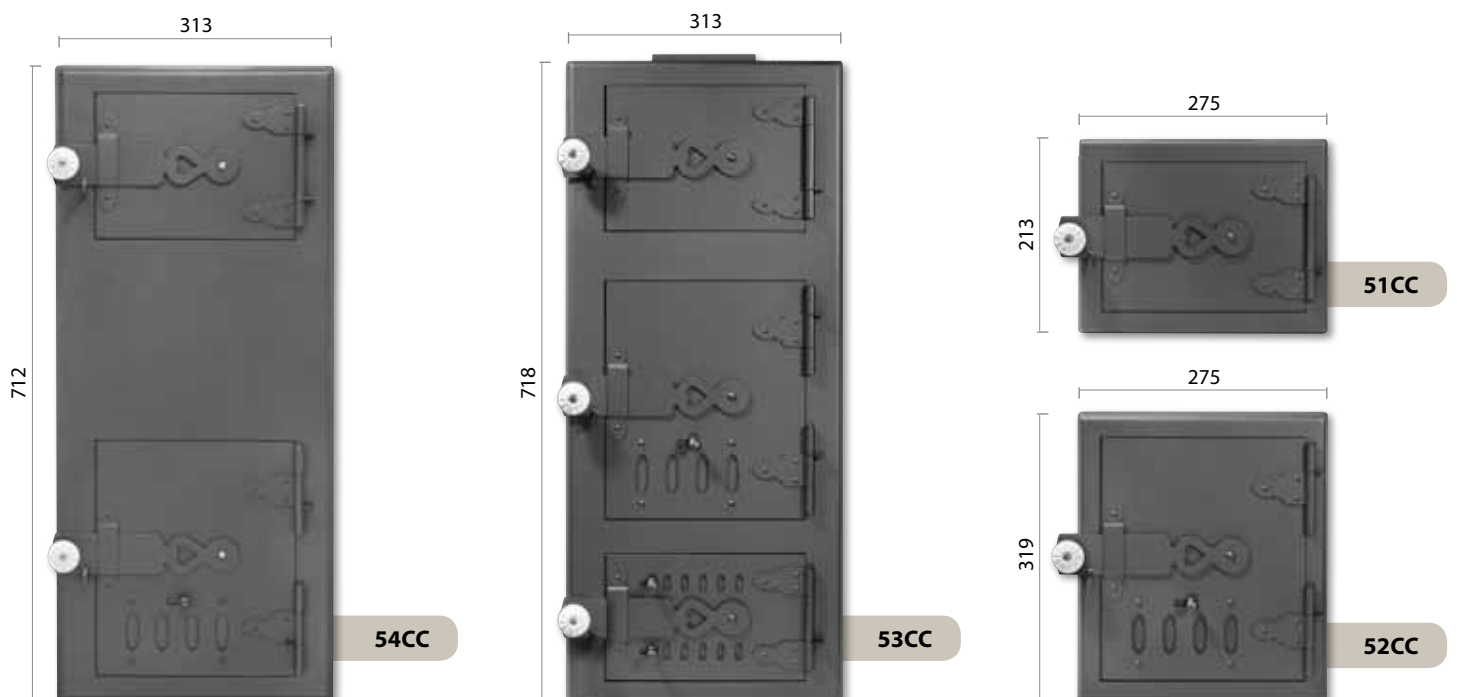

RÁMY, PLOTNY



45 Ocelová plotna sluníčko tl. 8, 10, 12 mm
vnější rozměry: na zakázku.



46 Ocelové pláty tl. 10 mm, vnější rozměry: na zakázku.



PŘÍSLUŠENSTVÍ



105 Rošt do trouby nerezový, š. 350, h. 440, v. 15 mm.



106 Talířník sklápěcí, š. 450, h. 300 mm.

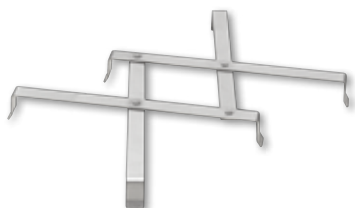

94 Čtyřnožka, š. 300, h. 190, v. 30 mm.



96 Rošt do trouby chromovaný, š. 350, h. 440, v. 20 mm.



93 3x sušící síto se stojanem, š. 295, h. 450, v. 165 mm.



95 Síto sušící do trouby, š. 350, h. 480, v. 15 mm.



100 Litinový rošt (bez rámečku), š. 180, h. 290, v. 18 mm.



104 Rámeček pod litinový rošt



P21 Popelník
š. 186, v. 95, h. 355 mm.



P CPV Popelník
š. 193, v. 113, h. 385 mm.



P69 Popelník
š. 225, v. 123, h. 425 mm.

KOUŘOVODY ø 150 mm



10CN Komínová dvířka, š. 225, v. 346 mm.



8190 T-kus 90°



8185 T-kus 85°



82500 Nástavec 500 mm



83 Vývod z kamen



821000 Nástavec 1000 mm



84 Koleno 45° otočné



85 Koleno 90° otočné



86 Koleno 90° pevné



87 Koleno 90° pevné s čistícím otvorem



88 Koleno 90° otočné s čistícím otvorem



89 Koleno 90° otočné čtyřdílné

KOUŘOVODY ø 150 mm C

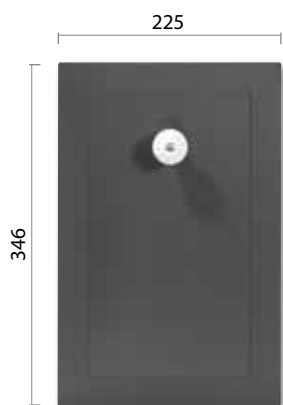

10CC Komínová dvířka, š. 225, v. 346 mm.



8190C T-kus 90°



8185C T-kus 85°

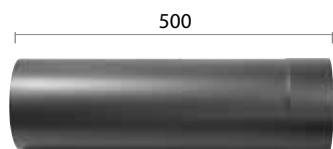

82C500 Nástavec 500 mm



82C1000 Nástavec 1000 mm



84C Koleno 45° otočné



85C Koleno 90° otočné



86C Koleno 90° pevné



87C Koleno 90° pevné s čistícím otvorem



88C Koleno 90° otočné s čistícím otvorem



89C Koleno 90° otočné čtyřdílné

BIOTOPENIŠTĚ

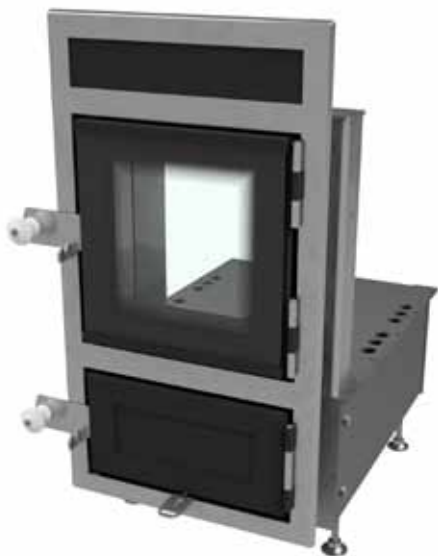

209

ZÁKLADNA PRO BIOTOPENIŠTĚ - PROSKLENÉ DVEŘE



201

BIOTOPENIŠTĚ KOMPLET SE ŠAMOTEM - PROSKLENÉ DVEŘE



401

CPV - CENTRÁLNÍ PŘISÁVÁNÍ VZDUCHU
DO POPELNÍKOVÉ KOMORY

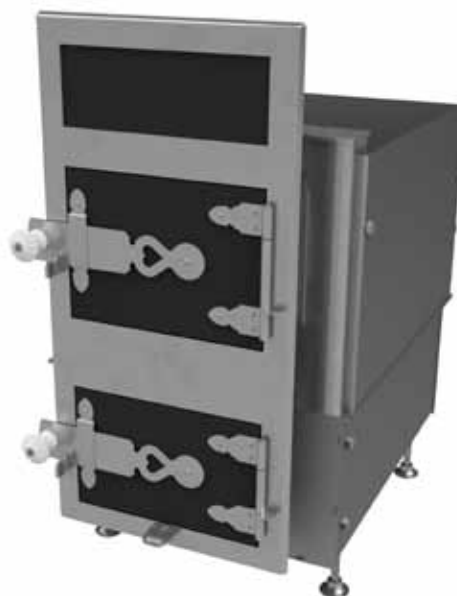

301

BIOTOPENIŠTĚ KOMPLET SE ŠAMOTEM - DVEŘE CN



ZIKMUND & HAVELKA

OD ROKU 1992 **VYRÁBÍME**

UCELENÉ **KOMPLETY**

KOVÁNÍ — VÝROBA I NA

ZAKÁZKU — **PRO KLASICKÁ**

KUCHYŇSKÁ **KACHLOVÁ**

KAMNA, PECE A UDÍRNÝ.

Váš prodejce:

Výrobce:

Zikmund & Havelka

Rohy 15, 675 05 Rudíkov, tel.: 568 875 390

E-mail: zikmund.havelka@seznam.cz, www.kovaninakamna.cz